



/usr/DT-grange/plans/s.Afmp2R125605361

A. INC. GMBH

NON GLASS HERMETIC RECEPTACLE  
SCREW-IN TYPE

SERIES: SMA

PANEL DRILLING

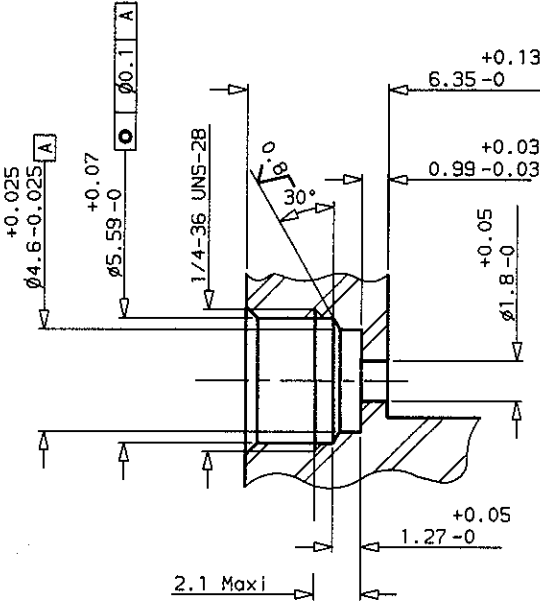

RECOMMENDED MOUNTING HOLE DETAIL

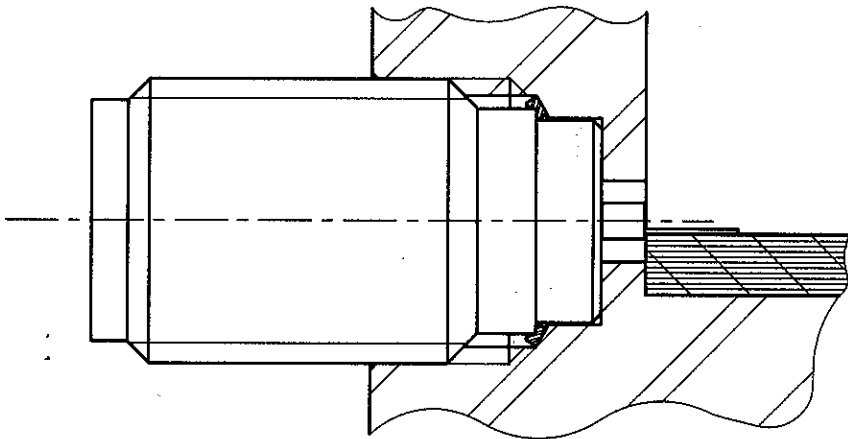

Assemble metal gasket onto connector. Screw both parts into the housing. Tighten the connector up to 25 Inch-Pounds torque (use special tooling set RADIALL R282 341 000).

ISSUE	REVISION No	DESCRIPTION	BY	DATE
.	.	.	.	.
.	.	.	.	.
.	.	.	.	.
.	.	.	.	.

Initiated on 12-10-88  
Superseded on 05-12-89

The information given here is subject to change without notice. Design changes may be in order to improve the product.

